

RONDA mastertech 7000

XXL Multifunctions,
Retrograde and Big Date

Caliber 7004.B – 15'''

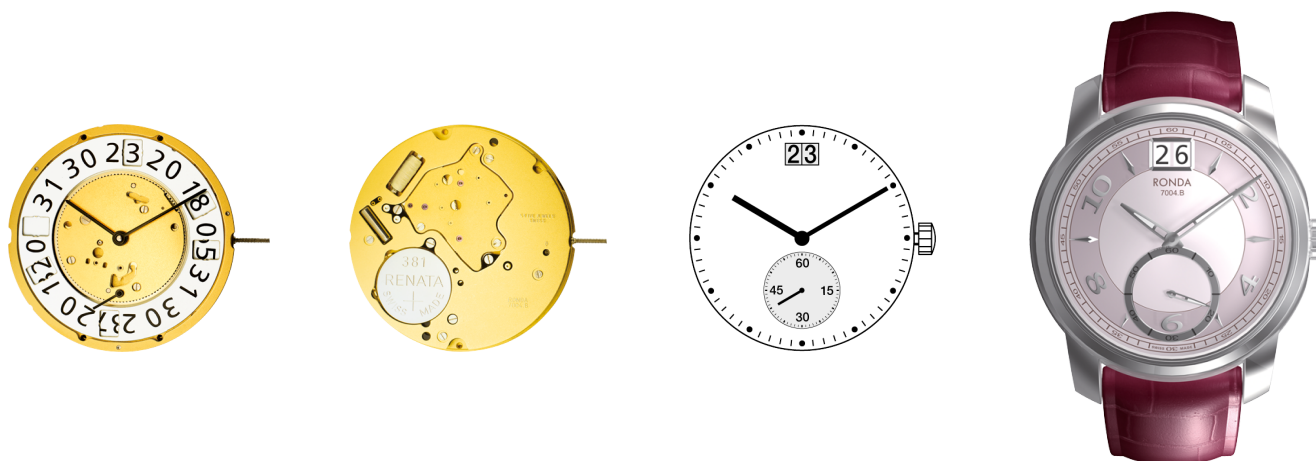

Product Specifications

Analog quartz movement	
Line	mastertech
Caliber	7004.B
Size	15'''
Version	Swiss Made
	6 Jewels / gold plated
Standard battery life	48 months
Hand fitting height	1

Features

- Repairable metal watch movement
- Very long battery life
- Power saving mechanism with pulled out stem: Reduction of consumption approximately 70%

Functions

- Big date
- Small second
- 2 hands

Technical Specifications

Diameter Total	34.60 mm
Case fitting	33.80 mm
Movement height	5.60 mm
Height over standard battery	5.60 mm
Movement rest	0.60 mm
Height over stem	3.30 mm
Length of stem travel	1.00 mm
Force to push the stem for screwed crown	10 / 15 N
Stem thread	0.90 mm
Standard battery	381
Standard battery life	48 months
Battery voltage	1.5 V
Current consumption – typical	1.43 μ A (Date Mechanism not in Gear)
Current consumption – maximum	3.1 μ A (Date Mechanism not in Gear)
Useful torque second – typical	10 μ Nm
Useful torque minute – typical	500 μ Nm
Operating temperature	0 - 50 °C
Instantaneous rate	-10/ +20 sec/month
Resistance to magnetic fields	18.8 Oe
Resistance against shock	NIHS 91-10



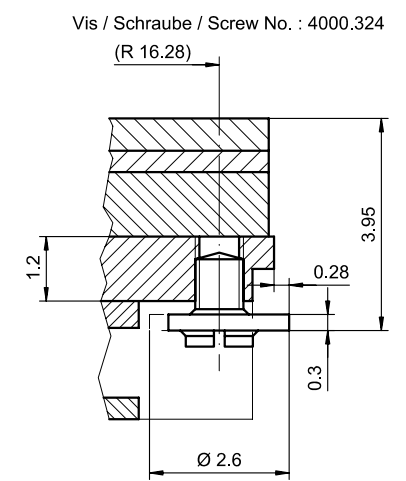
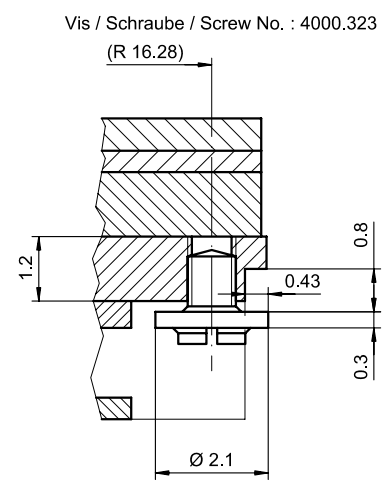
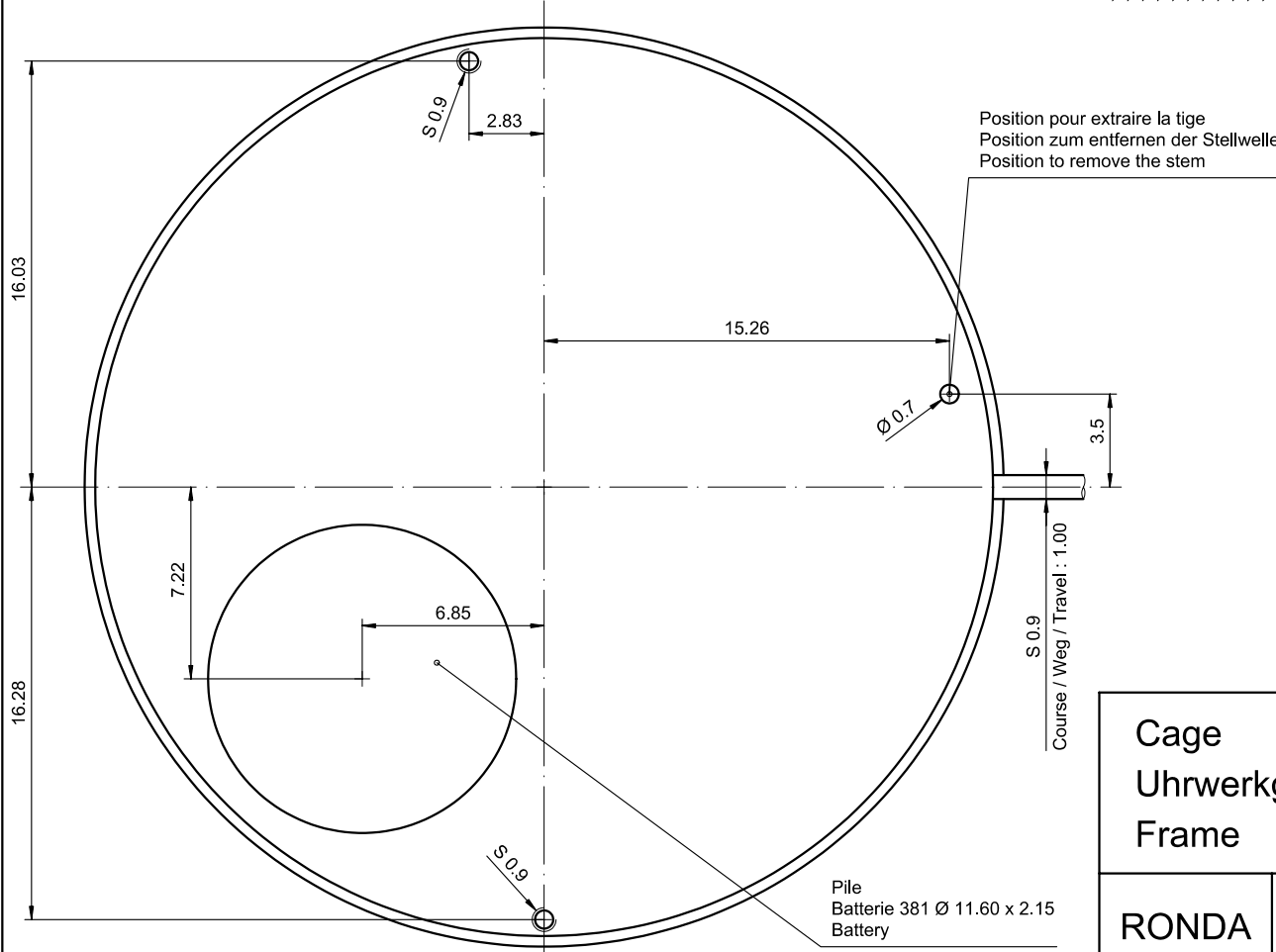
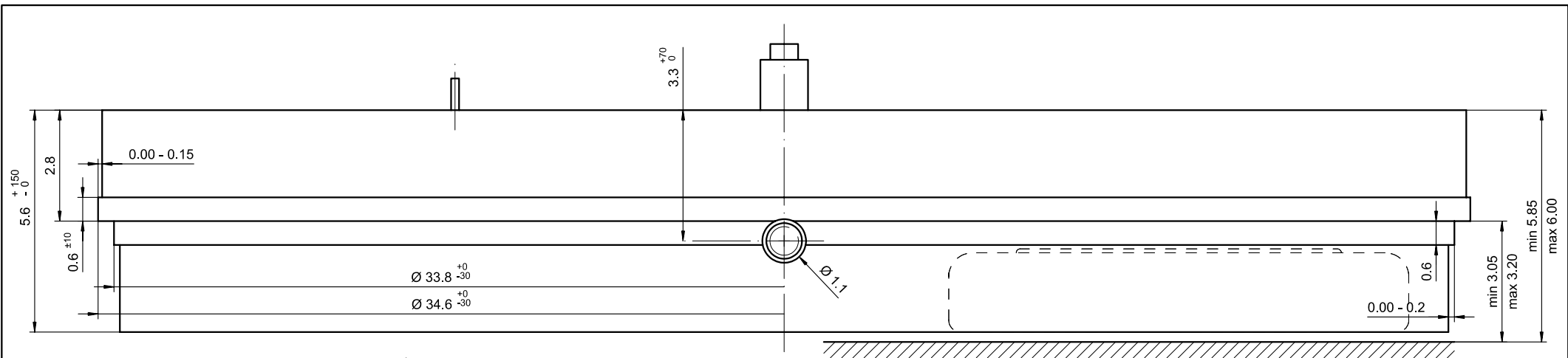

Sécurité entre l'aiguille des seconde et le verre : min 0.50 mm
 Sicherheit zwischen Sekundenzeiger und Glas : min 0.50 mm
 Security between second hand and glass : min 0.50 mm

Le cadran doit être tenu par la boîte.
 Das Zifferblatt muss durch die Schale gehalten werden.
 The dial must be hold by the case.

Cage Uhrwerkgestell Frame	15'''	
	Issued	22 Aug 2007 dh
	Modified	08.02.2010 dh AA 7724
	Released	YES
	Tolerance	+/- 20 µm
Scale	10 : 1 (5 : 1) (A3H)	
RONDA	7004.B	Sous réserve de modifications Änderungen vorbehalten Modifications reserved
		No. 5000.366 01

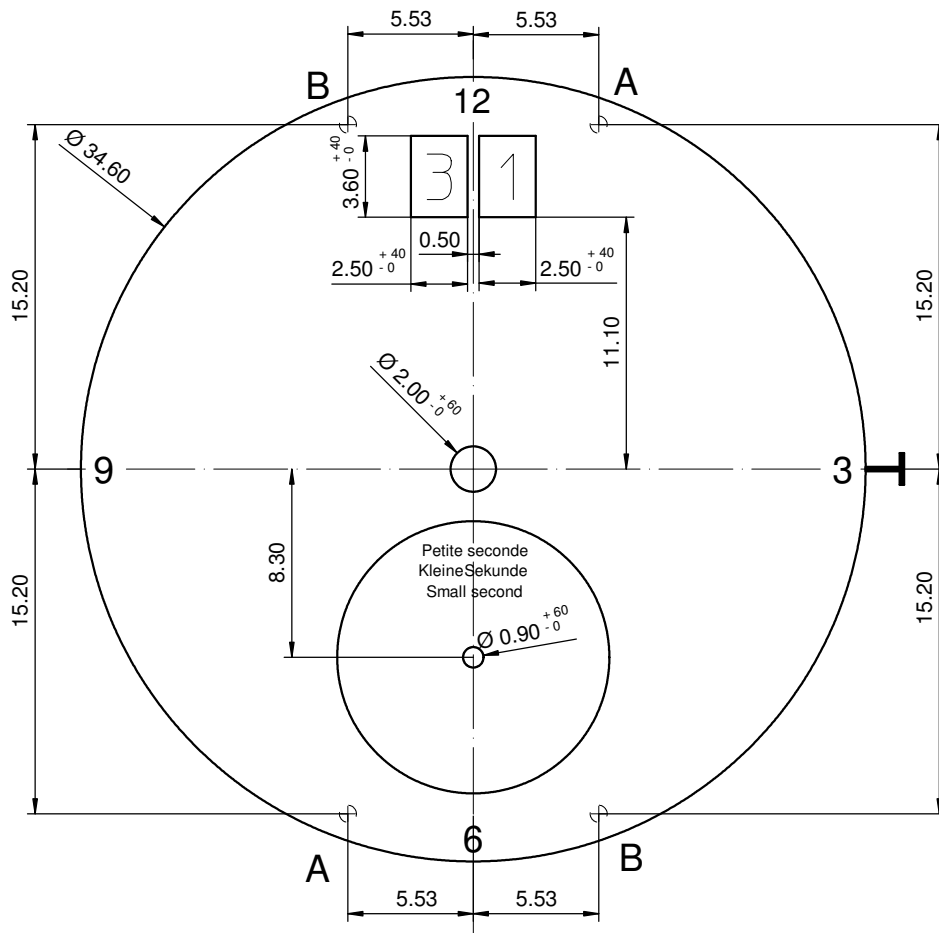

Disponibles positions pour pieds de cadran / Available dial feet positions / Verfügbare Zifferblatfußpositionen

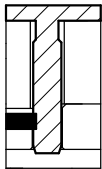
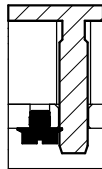
A Pos 1h / 7h	B Pos 5h / 11h
 <p>Fixation du cadran avec rondelle en plastique Dial fixation by plastic disc Zifferblattbefestigung durch Kunststoffscheibe</p>	 <p>Fixation du cadran avec clef de cadran Dial fixation by dial - key Zifferblattbefestigung durch Zifferblattschlüssel</p>

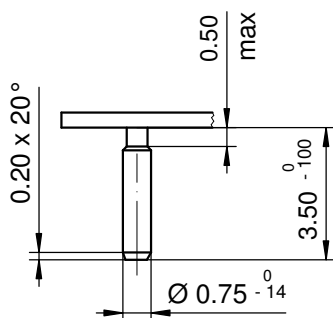

Epaisseur du cadran selon hauteur de l'aiguillage
Zifferblattdicke gemäss Zeigerwerkhöhen
Dial thickness according to hand fitting heights

Tige	Date
Stellw.	Datum
Stem	Date
3H	12H

Cadran Zifferblatt Dial	15"	Issued	28 Jun 2007	fl
		Modified	26 Nov 2012 ÄA 10475	dh
		Released	YES	
		Tolerance	+/- 20 µm	
		Scale	3 : 1 (A4V)	
RONDA	7004.B	Sous réserve de modifications Aenderungenvorbehalten Modifications reserved		
		No.	5010.636	01

Ajustement aiguille des minutes
Minutenzeigerpassung
Minute hand fitting

Ajustement aiguille des heures
Stundenzeigerpassung
Hour hand fitting

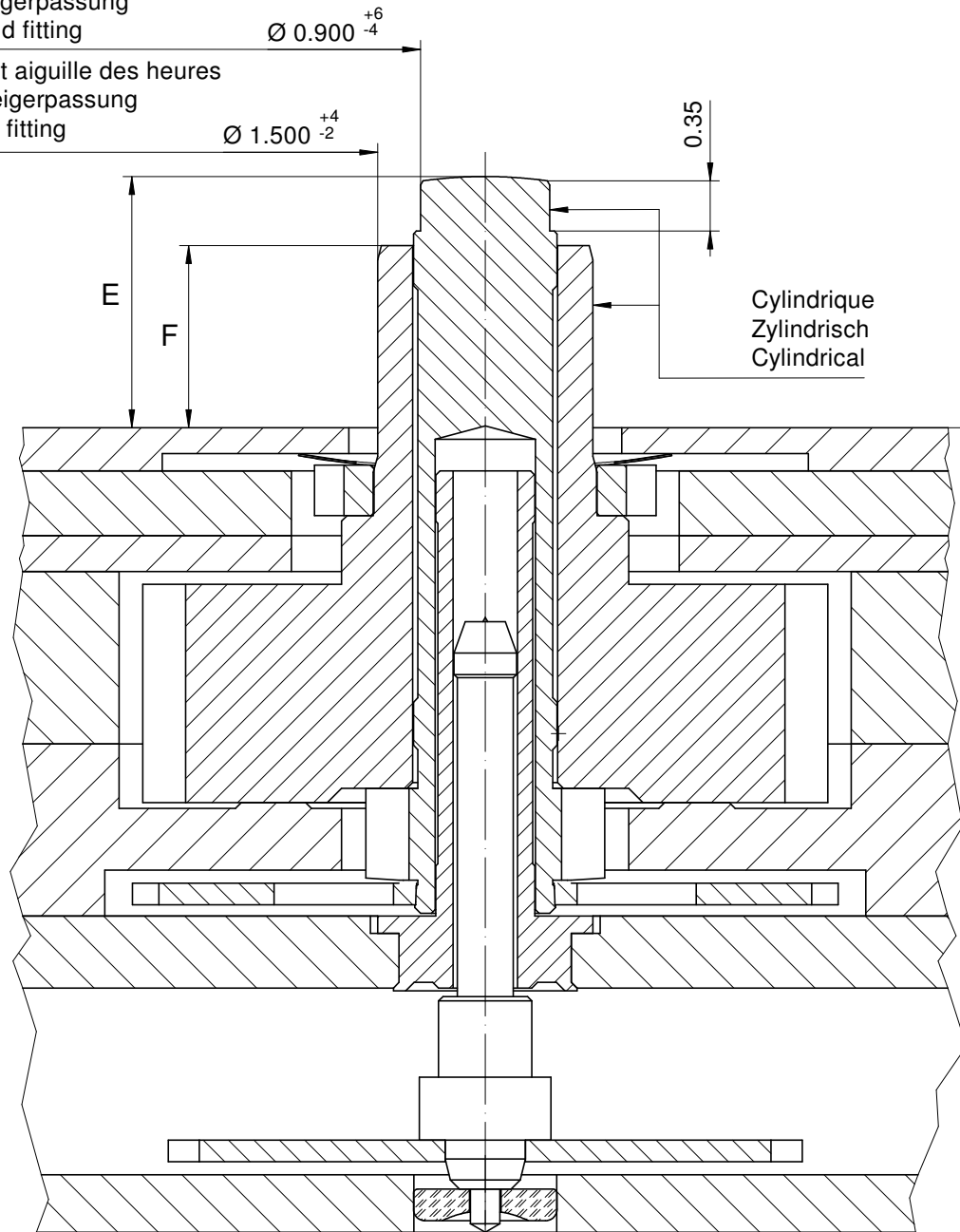

Heures / minutes
Stunden / Minuten
Hours / minutes

Ajustement aiguille
Zeigerpassung
Hand fitting

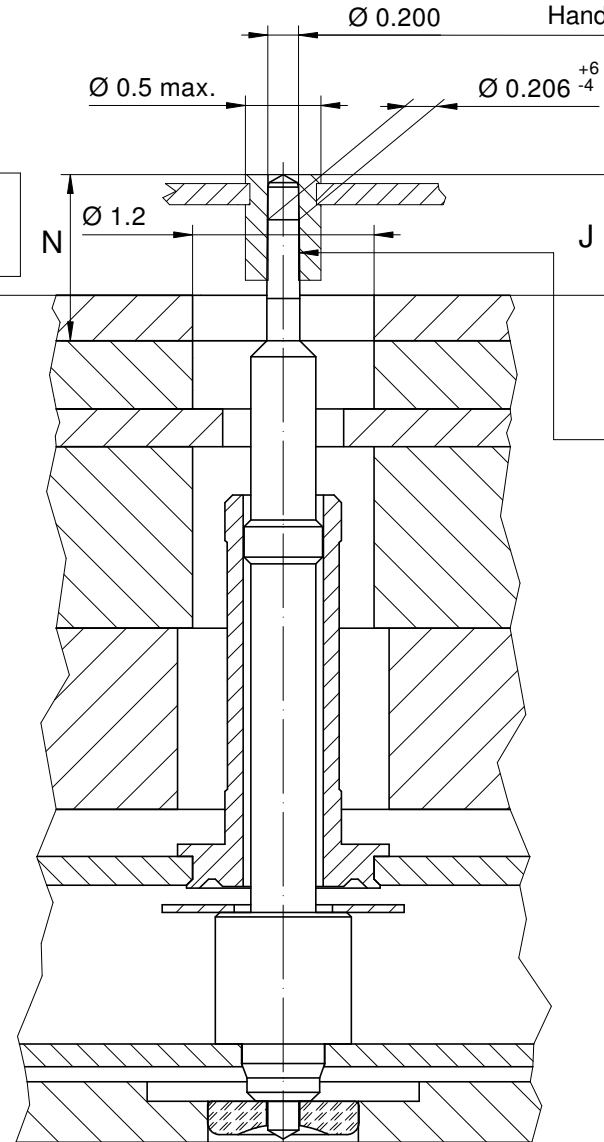

Petite seconde
Kleine Sekunde
Small second

Aiguillages Zeigerwerkhöhe Hand fitting height				
Dépassement Höhe über Zifferblattaufgabe Height over dial seat				
	Chaussée Minutenrohr Cannon-pinion	Roue des heures Stundenrad Hour wheel	Petite seconde Kleine Sekunde Small second	
No	E	F	J	N
1	1.75	1.27	0.80	1.10
-				

Aiguillages Zeigerwerkhöhe Hand fitting height				
Peinture comprise / inkl. Farbe / Paint included				
Epaisseur maximum du cadran Maximale Zifferblattstärke Maximum dial thickness				
No	Sous l'aiguille des minutes Unter Minutenzeiger Under minute hand	Sous l'aiguille des heures Unter Stundenzeiger Under hour hand	Sous l'aiguille de petite seconde Unter kleine Sekundenzeiger Under small second hand	Epaisseur des aiguilles Zeigerdicke Hands thickness
1	1.30	0.85	0.40	0.15
-				

	Aig. des minutes Minutenzeiger Minute hand	Aig. des heures Stundenzeiger Hour hand	Aig. petite secondes Kleine Sekundenzeiger Small second hand	Lors de la pose d'aiguilles, le mouvement doit être soutenu. Beim Zeigersetzen muss das Werk abgestützt werden. The movement needs to be supported for hand setting.
mg max.	30	30	10	Masse / Masse / Weight *
µNm max.	0.70	0.70	0.08	Balourd / Unwucht / Unbalance *
gmm ² max.	-	-	0.2	Inertie / Massenträgheit / Inertia *
N max.	40	40	30	Force de chassage / Aufpresskraft / Force

Aiguillages
Zeigerwerkhöhen 15"
Hand fitting heights

RONDA 7004.B

Issued	22 Aug 2007	dh
Modified	15 Okt 2014 ÄÄ 13275	dh
Released	YES	
Tolerance	µm	
Scale	20:1 (A3H)	
Sous réserve de modifications Änderungen vorbehalten Modifications reserved		
No.	3316.119	04

* En cas de données différentes, veuillez contacter le service après-vente

* Bei abweichenden Werten, bitte technischen Kundendienst anfragen

* In case of different values, please contact the customer service

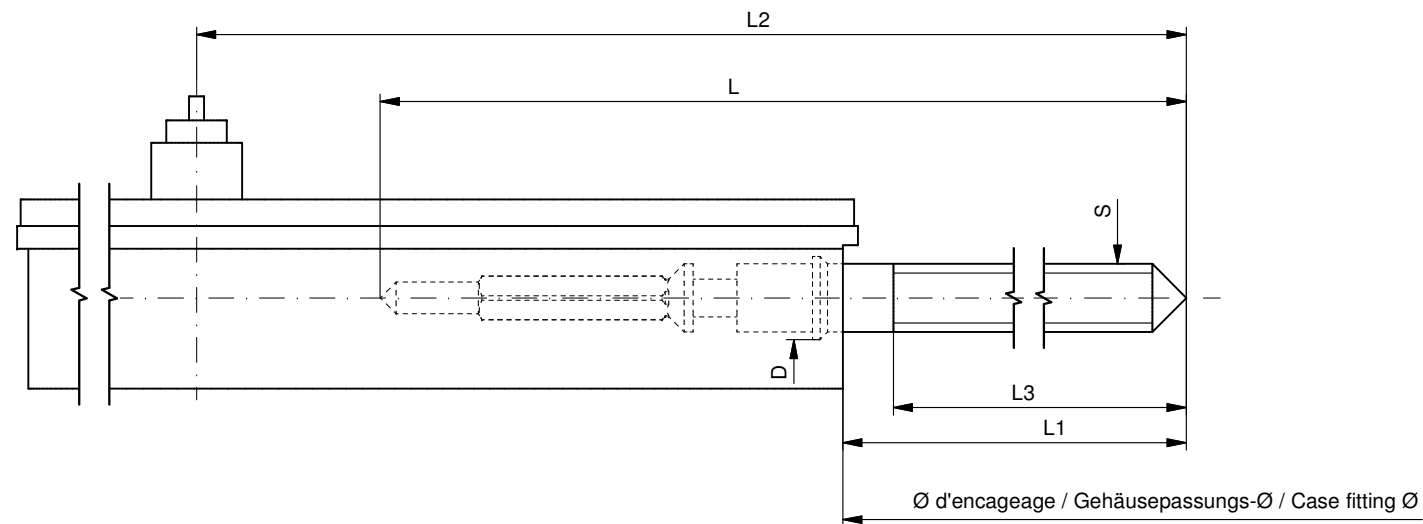

Tige de travail (intégrée dans le mouvement)
 Arbeitstellwelle (im Werk eingebaut)
 Working stem (implemented in the movement)

No. d'article Artikelnummer Part number	L	L1	L2	L3	S	D
3000.194.CO	21.30	10.74	27.64	10.15	0.90	1.10

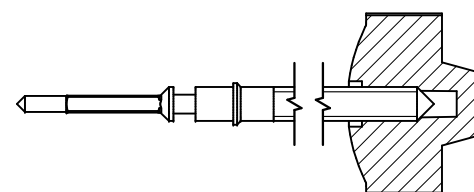

Couleur de la couronne Kronenfarbe Crown color	purple violett violet
Code	UN 5046

Tige (normale) / Stellwelle (normal) / Stem (normal)

No. d'article Artikelnummer Part number	L	L1	L2	L3	S	D
3000.194	21.30	10.74	27.64	10.15	0.90	1.10

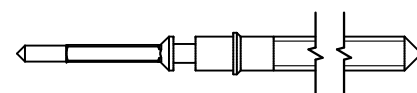

Couronne normale
 Normale Krone
 Normal crown

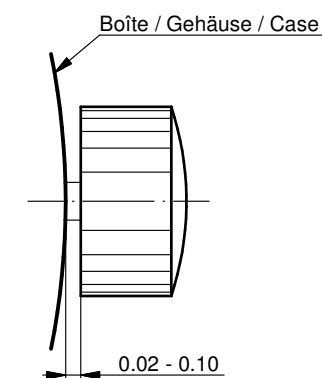

Couronne vissée
 Geschraubte Krone
 Screwed crown

Force ⇐ min. Kraft ⇐ min. Force ⇐ min.	10 N
Force ⇐ max. Kraft ⇐ max. Force ⇐ max.	15 N

Rallonge de tige / Stellwelle Verlängerung / Stem extension

No. d'article Artikelnummer Part number	L4	L5 (min)	L6	S1	S2	D1
3000.040	12.00	1.90	2.45	0.90	0.90	1.35

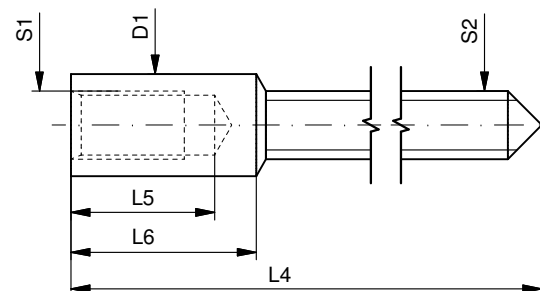

Tige (dimensions / forces)
 Stellwelle (Dimensionen / Kräfte)
 Stem (dimensions / forces)

RONDA

7003.B, 7003.L, 7003.N,
 7004.B, 7004.N, 7004.P

Issued	06 Sep 2012	ds5222
Modified	---	ds5222
Released	ÄA 11741	
Tolerance	YES	
Scale	10:1 (A3)	

Sous réserve de modifications
 Änderungen vorbehalten
 Modifications reserved

No.	5030.022	00
-----	----------	----



Movement holder
Removing setting stem
 H7XXX.1T



Movement holder
Setting hands
 H7XXX.1A

Fitting dial and hands

- Crown in position II
- Wind crown until date 02 appears
- Crown in position III
- Wind hour hand forwards, until date changes to 03
- Remove working hand
- Fit dial
- Set retrograde hand on Sunday
- Point remaining hands towards 12 o'clock
- Wind time forwards, in order to set actual weekday
- Set time
- Crown in position II
- Set date
- Crown in position I

Date switching duration

First and tenth digit discs

~2hrs

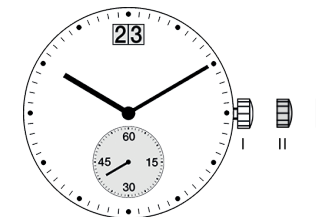
General Instructions

Removing the setting stem can only be effected in Pos. I.

The use of supporting screws is essential when mounting the hands.

Permitted hand setting strengths:

Hr / min. hands: <40N

Other hand: <30N

During quick date correction (setting stem in position II), a date switching speed of 5 d/s must not be exceeded.

	Werkhalter T2 Porte-pièce T2 Movement holder T2	DOMVT004
		Version: 1.7
	Verwendung & Übersicht Utilisation & Vue d'ensemble Utilisation & Overview	Prozess: 3.1.3
		Änd.-Dat.: 06.06.2012

→ 5110, 5112, 5150, 5151, 5152, 5160, 5161, 5163, 5164, 5166, 5310, 5311, 5312, RTC, RHK

→ Ermano, Pine Precision

→ AF Switzerland SA, Horotec SA, Tschudin & Schneider

	A Zeiger setzen Poser les aiguilles Hand setting	T Stellwelle entfernen Enlever la tige Stem removal	Diverses Divers Various
Kalibergruppe Groupe de calibre Calibre group	Artikelnummer Numéro d'article Part number	Artikelnummer Numéro d'article Part number	Artikelnummer Numéro d'article Part number

8000-8499
8040.B 8040.N











7000-7999
700X.B 700X.L 700X.N 700X.P

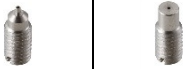

Wichtig! Die Höhe der Abstützschrauben muss vor Beginn jeder Serie eingestellt werden.

Important! Veuillez ajuster l'hauteur des vis de support au préalable de chaque série.

Important! Adjust height of support screws prior to each series.

	<p>A Zeiger setzen Poser les aiguilles Hand setting</p>	<p>T Stellwelle entfernen Enlever la tige Stem removal</p>	<p>P Alarm-Check Contrôle d'alarme Alarm check</p>
<p>Kalibergruppe Groupe de calibre Calibre group</p>	<p>Artikelnummer Numéro d'article Part number</p>	<p>Artikelnummer Numéro d'article Part number</p>	<p>Artikelnummer Numéro d'article Part number</p>
<p>6000-6999</p> <p>6XXX.B 6XXX.D</p>	<p>H 6XXX.1A</p>  <p>Swiss Made Swiss Parts</p> 	<p>H 6XXX.1T</p> 	
<p>4000-5999.B/.C/.D/.E</p> <p>4XXX.B 5XXX.B 5XXX.C 5XXX.D 5XXX.E</p>	<p>H 5XXX.1A</p> 	<p>H 5XXX.1T</p> 	<p>H 5XXX.1P</p> 
<p>4000-5999.F</p> <p>5XXX.F (4XXX.B) (5XXX.B) (5XXX.C) (5XXX.D) (5XXX.E)</p>	<p>H 5XXX.FA</p> 	<p>H 5XXX.1T</p> 	<p>H 5XXX.1P</p> 

Wichtig! Die Höhe der Abstützschrauben muss vor Beginn jeder Serie eingestellt werden.
Important! Veuillez ajuster l'hauteur des vis de support au préalable de chaque série.
Important! Adjust height of support screws prior to each series.

	A Zeiger setzen Poser les aiguilles Hand setting	T Stellwelle entfernen Enlever la tige Stem removal	Diverses Divers Various
Kalibergruppe Groupe de calibre Calibre group	Artikelnummer Numéro d'article Part number	Artikelnummer Numéro d'article Part number	Artikelnummer Numéro d'article Part number

3500-3999
3520.D 3540.D



1062-1069
1062 1063 1064 1069
1062
1063
1064
1069

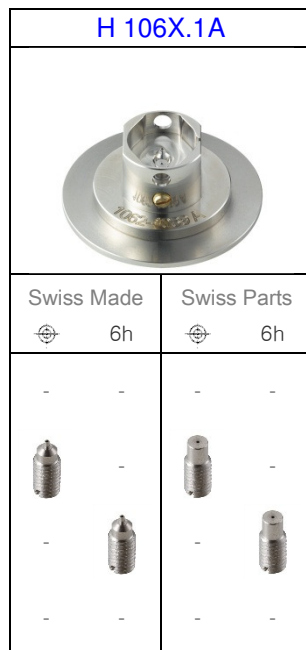

1042
1042



Wichtig! Die Höhe der Abstützschrauben muss vor Beginn jeder Serie eingestellt werden.
Important! Veuillez ajuster l'hauteur des vis de support au préalable de chaque série.
Important! Adjust height of support screws prior to each series.

	A Zeiger setzen Poser les aiguilles Hand setting	T Stellwelle entfernen Enlever la tige Stem removal	Diverses Divers Various
Kalibergruppe Groupe de calibre Calibre group	Artikelnummer Numéro d'article Part number	Artikelnummer Numéro d'article Part number	Artikelnummer Numéro d'article Part number
1032 1032	H 1032.1A 	H 1032.1T 	
1012-1019 1012 1013 1014 1015 1016 1019	H 101X.1A 	H 101X.1T 	
1002-1009 1002 1003 1004 1005 1006 1009	H 100X.1A 	H 100X.1T 	

Wichtig! Die Höhe der Abstützschrauben muss vor Beginn jeder Serie eingestellt werden.
Important! Veuillez ajuster l'hauteur des vis de support au préalable de chaque série.
Important! Adjust height of support screws prior to each series.



	A Zeiger setzen Poser les aiguilles Hand setting	T Stellwelle entfernen Enlever la tige Stem removal	Diverses Divers Various
Kalibergruppe Groupe de calibre Calibre group	Artikelnummer Numéro d'article Part number	Artikelnummer Numéro d'article Part number	Artikelnummer Numéro d'article Part number

782-788
782 783 784 785 788

H 78X.1A	
	
Swiss Made	Swiss Parts
	

H 78X.1T

772-775
772 773 774 775





H 77X.1A	
	
Swiss Made	Swiss Parts
	

H 77X.1T

Wichtig! Die Höhe der Abstützschrauben muss vor Beginn jeder Serie eingestellt werden.
Important! Veuillez ajuster l'hauteur des vis de support au préalable de chaque série.
Important! Adjust height of support screws prior to each series.

	A Zeiger setzen Poser les aiguilles Hand setting	T Stellwelle entfernen Enlever la tige Stem removal	Diverses Divers Various
Kalibergruppe Groupe de calibre Calibre group	Artikelnummer Numéro d'article Part number	Artikelnummer Numéro d'article Part number	Artikelnummer Numéro d'article Part number

762-763
762 762E 763 763E
762 762E 763 763E

H 76X.1A	
	
Swiss Made	Swiss Parts
-	-
-	-
	-
	



751-753
751 753
751 753



H 75X.1A	
	
Swiss Made	Swiss Parts
-	-
	



Wichtig! Die Höhe der Abstützschrauben muss vor Beginn jeder Serie eingestellt werden.
Important! Veuillez ajuster l'hauteur des vis de support au préalable de chaque série.
Important! Adjust height of support screws prior to each series.



	A Zeiger setzen Poser les aiguilles Hand setting	T Stellwelle entfernen Enlever la tige Stem removal	Diverses Divers Various
Kalibergruppe Groupe de calibre Calibre group	Artikelnummer Numéro d'article Part number	Artikelnummer Numéro d'article Part number	Artikelnummer Numéro d'article Part number

712-715
712 713 714 715

H 71X.1A	
	
Swiss Made	Swiss Parts
	

H 71X.1T

702-708
702 703 704 705 708 (706)

H 70X.1A	
	
Swiss Made	Swiss Parts
	







H 70X.1T

706
706.1 706.2 706.3 706.B

H 706.1A	
	
Swiss Made	Swiss Parts
⊕ 6h	⊕ 6h
 	 

H 70X.1T

Wichtig! Die Höhe der Abstützschrauben muss vor Beginn jeder Serie eingestellt werden.
Important! Veuillez ajuster l'hauteur des vis de support au préalable de chaque série.
Important! Adjust height of support screws prior to each series.

	A Zeiger setzen Poser les aiguilles Hand setting	T Stellwelle entfernen Enlever la tige Stem removal	Diverses Divers Various
Kalibergruppe Groupe de calibre Calibre group	Artikelnummer Numéro d'article Part number	Artikelnummer Numéro d'article Part number	Artikelnummer Numéro d'article Part number
582-585 582 583 585	H 58X.1A 	H 58X.1T 	
512-519 512 513 515 517 519	H 51X.1A 	H 51X.1T 	
502-509 502 503 505 507 509	H 50X.1A 	H 50X.1T 	

Wichtig! Die Höhe der Abstützschrauben muss vor Beginn jeder Serie eingestellt werden.
Important! Veuillez ajuster l'hauteur des vis de support au préalable de chaque série.
Important! Adjust height of support screws prior to each series.

User's Manual English

Movements Caliber

RONDA powertech

– 585
– 505
– 515

RONDA slimtech

– 1005
– 1006
– 1009
– 1015
– 1016
– 1019

RONDA normtech

– 774 – 6003.D
– 775 – 6004.D
– 704 – 6003.B
– 705 – 6004.B
– 784
– 785
– 714
– 715
– 715Li

RONDA mastertech

– 7002.B
– 7003.B
– 7004.B

You have decided to buy a watch, which was assembled by a watchmaker using a Ronda movement. Please note that no watches are produced or distributed under the Ronda brand.

In case of repairs, guarantee claims and questions concerning the functioning of a watch, purchasers and consumers should contact their retailer or the watch manufacturer, for which the relevant information can be found in the sales or guarantee documentation provided with the watch.

Cal. 585 / 785:

Battery type: 362/SR721SW (Ø 7.9 mm x 2.1 mm)

Cal. 774 / 775 / 784:

Battery type: 364/SR621SW (Ø 6.8 mm x 2.1 mm)

Cal. 505 / 515 / 704 / 705 / 714 / 715:

Battery type: 371/SR920SW (Ø 9.5 mm x 2.05 mm)

Cal. 6003.D / 6004.D / 6003.B / 6004.B:

Battery type: 373/SR916SW (Ø 9.5 mm x 1.6 mm)

Cal. 1005 / 1006 / 1009 / 1015 / 1016 / 1019:

Battery type: 341/SR714SW (Ø 7.9 mm x 1.4 mm)

Cal. 7002.B / 7003.B / 7004.B:

Battery type: 381/SR1120SW (Ø 11.6 mm x 2.05 mm)

Cal. 715Li:

Battery type: CR 2016 (Ø 20 mm x 1.6 mm)

Precision: +20/-10 seconds per month

Cal. 585

Cal. 6003.D

Cal. 505

Cal. 6004.D

Cal. 515

Cal. 6003.B

Cal. 6004.B

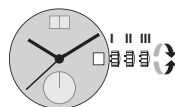

Pos. I Position of rest (watch running)

Pos. II Quick-change correction for date

The date can also be corrected during the day-changing phase between 10 pm and midnight. The date of the following day has to be set, because no automatic date change takes place at midnight.

- Pull the crown out to position II (watch still running).
- Turn the crown clockwise until the required date appears.

Cal. 6003.D & 6004.D:

- Turn the crown until the required date appears.
- Push the crown back into position I.

Pos. III Setting the time

- Pull the crown out to position III (watch stopped).
- Turn the crown, until the current time is displayed (remember the 24-hour cycle).
- Push the crown back into position I.

Cal. 774

Cal. 715Li

Cal. 775

Cal. 704

Cal. 1005

Cal. 705

Cal. 1006

Cal. 784

Cal. 1009

Cal. 785

Cal. 1015

Cal. 714

Cal. 1016

Cal. 715

Cal. 1019



Pos. I Position of rest (watch running)

Pos. II Quick-change correction for date

Blocking time for the quick-change day correction is from approx. 9.30 pm and midnight.

- Pull the crown out to position II (watch still running).
- Turn the crown until the current date appears.
- Push the crown back into position I.

Pos. III Setting the time

- Pull the crown out to position III (watch stopped).
- Turn the crown, until the current time is displayed (remember the 24-hour cycle).
- Push the crown back into position I.

Cal. 7002.B

Cal. 7003.B

Cal. 7004.B



Pos. I Position of rest (watch running)

Pos. II Quick-change correction for date

The date can also be changed during the day-changing phase between approx. 8.00 pm and midnight.









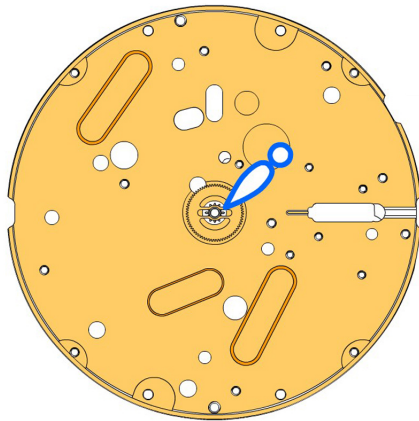
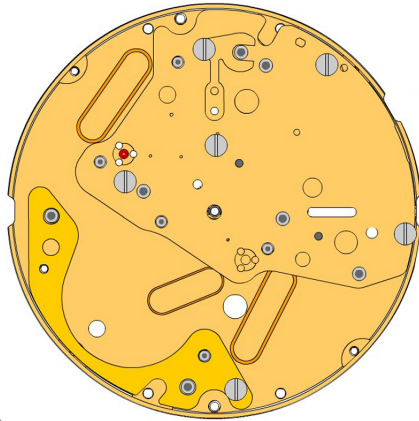
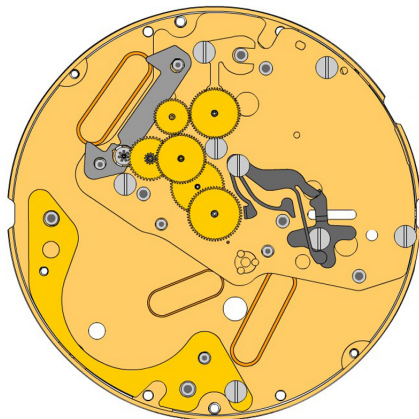









The date of the following day has to be set, because no automatic date change takes place at midnight.

- Pull the crown out to position II (watch still running).
- Turn the crown until the current date appears.
- Push the crown back into position I.

Pos. III Setting the time

- Pull the crown out to position III (watch stopped).
- Turn the crown, until the current time is displayed (remember the 24-hour cycle).
- Push the crown back into position I.

A

B

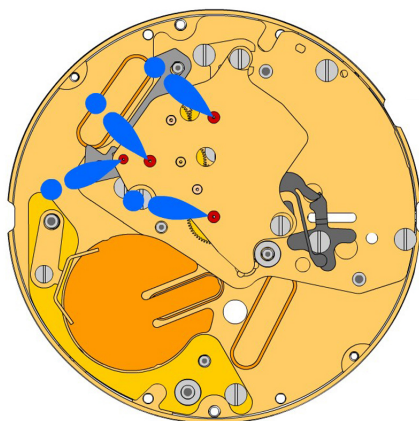
C

2000.669.G 1.		Main Plate
3305.363.CO 2.		Cannon pinion with driver B (Aig.1)
2030.028.CO 3.		Centre bridge Centre bridge held by 3 screws 4000.250.
4000.250 4.		Screw
3406.039 5.		Sliding attachment Sliding attachment held by 1 screw 4000.250.
2130.181.CO 6.		Combined maintaining plate Combined maintaining plate held by 1 screw 4000.250.
4000.250 7.		Screw
3016.028 8.		Lever for setting lever Lever for setting lever held by 1 screw 4000.249.
4000.249 9.		Screw
3016.027 10.		Stop lever Stop lever Position held by 1 screw 4000.249.
4000.249 11.		Screw
3622.044 12.		Stator
3715.105.RK 13.		Rotor
3147.060.CO 14.		Intermediate wheel
3122.070.CO 15.		Third wheel
3136.174.CO 16.		Centre second wheel (Aig.1)
3004.203.CO 17.		Seconde intermediate wheel
3136.182.CO 18.		Small second wheel
3136.173.CO 19.		Centre second wheel (Aig.1)

D

2020.170.G
20.  **Train wheel bridge**
Train wheel bridge held by 3 screws 4000.250.

4000.244
21.  **Screws**

3603.080
22.  **Battery insulator**

3601.120.G
23.  **Battery clamp +**
Battery clamp held by 1 screw 4000.248.

4000.248
24.  **Screw**

3503.071
25.  **Tube**

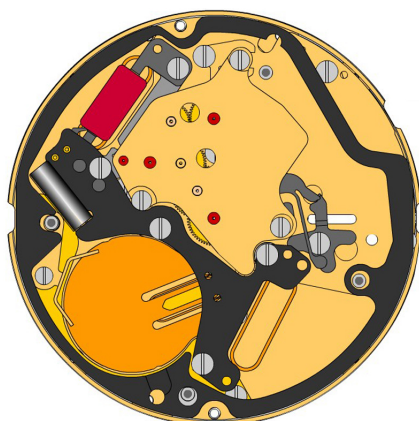
E

3612.196
26.  **Electronic module**
Electronic module held by 5 screws 4000.250.

4000.250
27.  **Screw**

3603.081
28.  **Spacer**

4000.244
29.  **Screws**

3600.032.HGF
30.  **Battery 381**

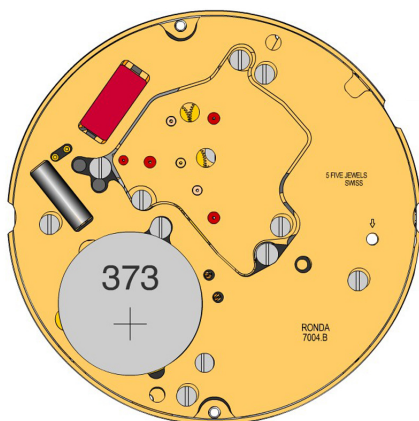
F

2000.669.G
31.  **Main Plate**

3017.054.CO
32.  **Setting lever**

3905.063
33.  **Setting lever jumper (3 positions)**
Setting lever jumper held by 1 screw 4000.282.

4000.282
34.  **Screw**

3001.061.FI
35.  **Sliding pinion**

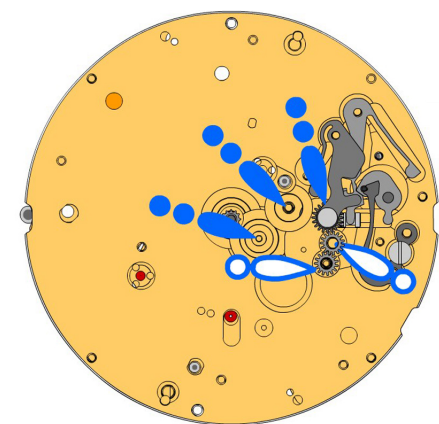

G

3015.077
36.  **Yoke (3 positions)**
Tensioning the spring arm.

3004.200
37.  **Corrector setting wheel**

3004.200
38.  **Corrector setting wheel**

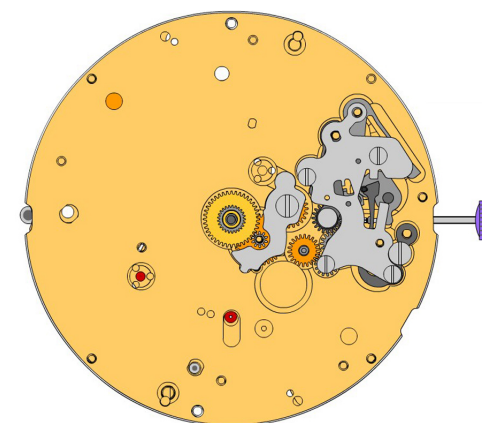
3015.078.CO
39.  **Rocking bar (3 positions)**
Tensioning the spring arm.

H

2130.194
40.  **Setting mechanism cover**
Setting mechanism cover held by 4 screws 4000.305.

4000.305
41.  **Screws**

3000.194.CO
42.  **Stem**

3004.204
43.  **Intermediate setting wheel**

3007.079.CO
44.  **Minute wheel**





2130.185
45.  **Minute train bridge**
Minute train bridge held by 1 screw 4000.278.

4000.278
46.  **Screw**

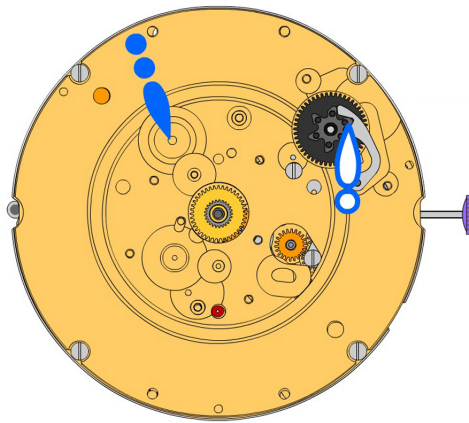



3301.296.CO
47.  **Hour wheel (Aig.1)**

3147.066.CO
48.  **Date corrector setting wheel**

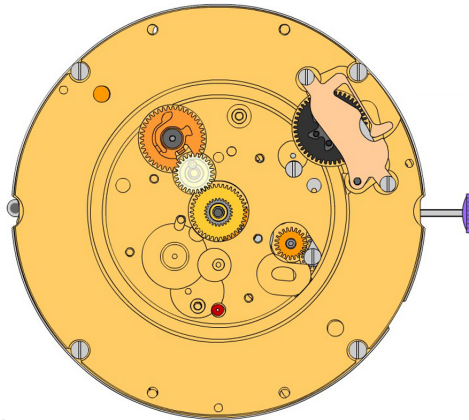



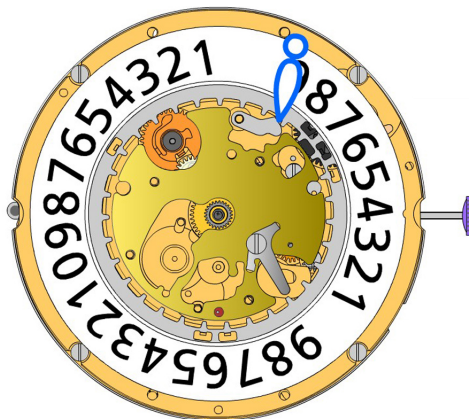

I

2000.671.G 49.		Main plate retro Main plate retro held by 4 screws 4000.248.
4000.248 50.		Screw
3004.220 51.		Tens indicator driving wheel The short tooth of the tens indicator driving wheel must point to the center of the movement.
3500.072 52.		Tens jumper

J



2130.187 53.		Tens jumper maintaining plate Tens jumper maintaining plate held by 2 screws 4000.279. Tensioning the spring arm.
4000.279 54.		Screw
3004.208.CO 55.		Date indicator driving wheel
3147.061 56.		Intermediate date wheel



K

2130.188 57.		Date indicator plate
3905.068 58.		Date corrector spring Date corrector spring held by 1 screw 4000.244.
3905.066 59.		Day rack lever spring Tensioning the spring arm.
3500.069 60.		Day jumper Tensioning the spring arm.
3500.068 61.		Date jumper
3504.229.AF.1.A 62.		Units indicator (standard) Nick of the indicator at 3 o'clock.



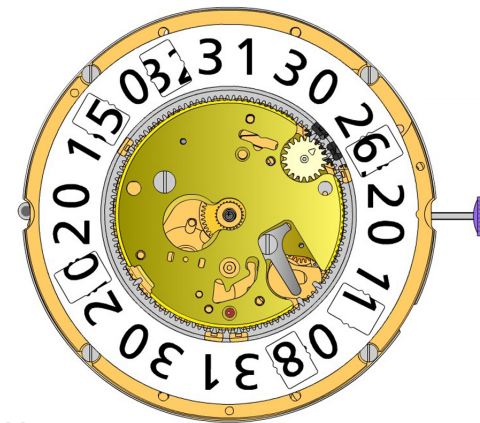

L

2130.189 63.		Date indicator maintaining plate Date indicator maintaining plate held by 1 screw 4000.250.
4000.250 64.		Screw
3905.064 65.		Date jumper spring Insert the date jumper spring in the provided opening.











M

3147.062 66.		Tens intermediate wheel Arrow positioning radially outwards.
3315.003 67.		Friction spring
3504.230.AF.1.A 68.		Tens indicator (standard) Nick of the indicator at 3 o'clock.



N

2130.190.G 69.		Date mechanism maintaining plate (12h) Date mechanism maintaining plate held by 3 screws 4000.320.
4000.320 70.		Screw
3506.077.G 71.		Intermediate dial support Polished version first.
3506.076.G 72.		Dial support

8200 73.		Moebius 8200
9014 74.		Moebius 9014
124 75.		Jismaa 124
9020 76.		Moebius 9020

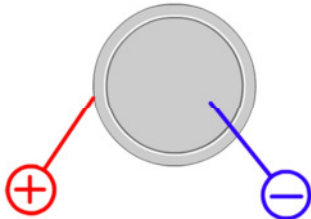

Battery	381
Voltage	1.55V

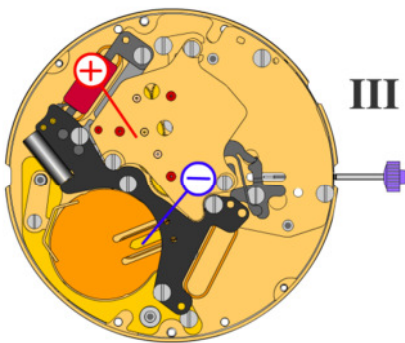

III *Setting stem in position III,
60s measuring interval:*

Typical consumption	0.1 μA
Maximal consumption	0.3 μA

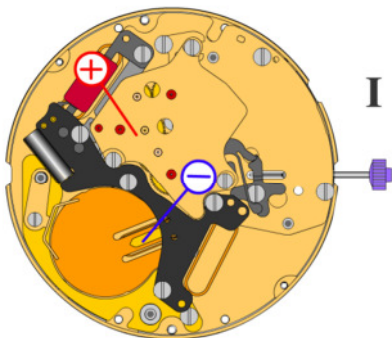

I *Stem in position I, date
mechanism not in gear:*

Typical consumption	1.43 μA
Maximal consumption	3.1 μA

60s measuring time:
Instantaneous rate **-10s/mth .. +20s/mth**

Lower working voltage limit	1.20 V
-----------------------------	---------------

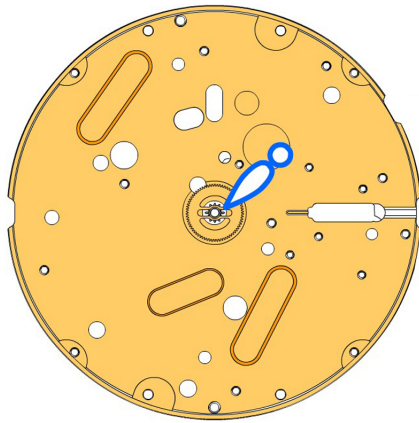



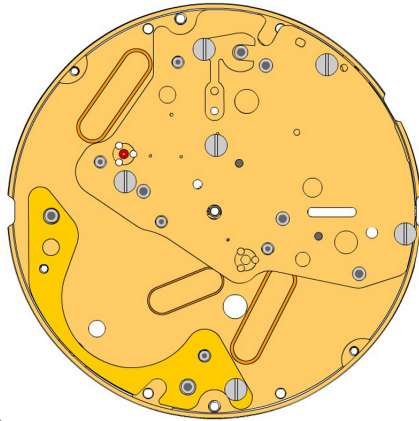



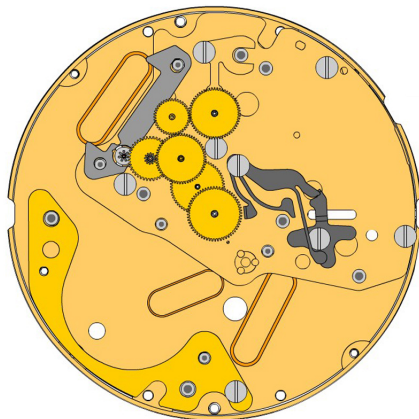











A





B

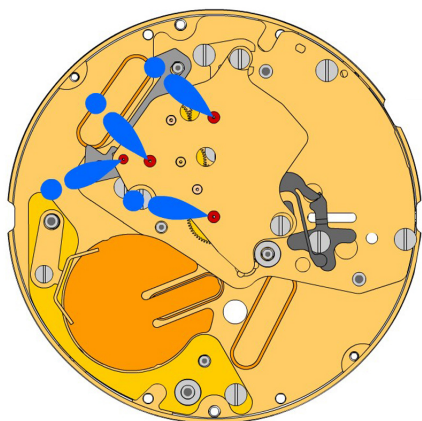

C

2000.669.G 1.		Main Plate
3305.363.CO 2.		Cannon pinion with driver B (Aig.1)
2030.028.CO 3.		Centre bridge Centre bridge held by 3 screws 4000.250.
4000.250 4.		Screw
3406.039 5.		Sliding attachment Sliding attachment held by 1 screw 4000.250.
2130.181.CO 6.		Combined maintaining plate Combined maintaining plate held by 1 screw 4000.250.
4000.250 7.		Screw
3016.028 8.		Lever for setting lever Lever for setting lever held by 1 screw 4000.249.
4000.249 9.		Screw
3016.027 10.		Stop lever Stop lever Position held by 1 screw 4000.249.
4000.249 11.		Screw
3622.044 12.		Stator
3715.105.RK 13.		Rotor
3147.060.CO 14.		Intermediate wheel
3122.070.CO 15.		Third wheel
3136.174.CO 16.		Centre second wheel (Aig.1)
3004.203.CO 17.		Seconde intermediate wheel
3136.182.CO 18.		Small second wheel
3136.173.CO 19.		Centre second wheel (Aig.1)

D

2020.170.G
20.  **Train wheel bridge**
Train wheel bridge held by 3 screws 4000.250.

4000.244
21.  **Screws**

3603.080
22.  **Battery insulator**

3601.120.G
23.  **Battery clamp +**
Battery clamp held by 1 screw 4000.248.

4000.248
24.  **Screw**

3503.071
25.  **Tube**

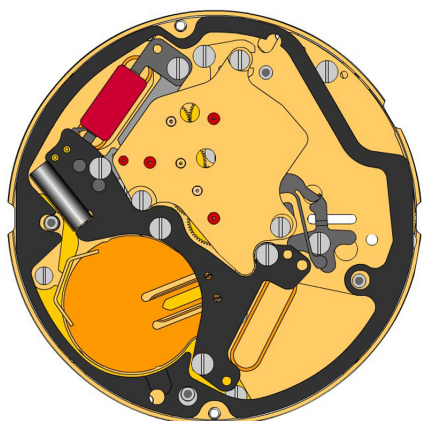
E

3612.196
26.  **Electronic module**
Electronic module held by 5 screws 4000.250.

4000.250
27.  **Screw**

3603.081
28.  **Spacer**

4000.244
29.  **Screws**

3600.032.HGF
30.  **Battery 381**

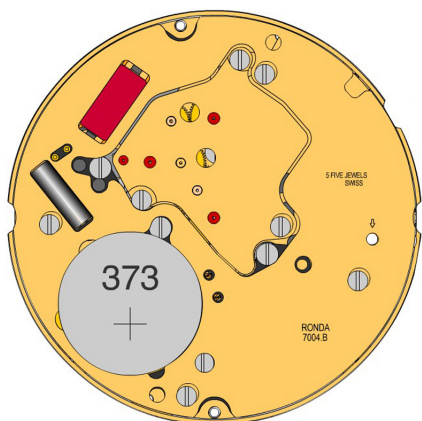
F

2000.669.G
31.  **Main Plate**

3017.054.CO
32.  **Setting lever**

3905.063
33.  **Setting lever jumper (3 positions)**
Setting lever jumper held by 1 screw 4000.282.

4000.282
34.  **Screw**

3001.061.FI
35.  **Sliding pinion**

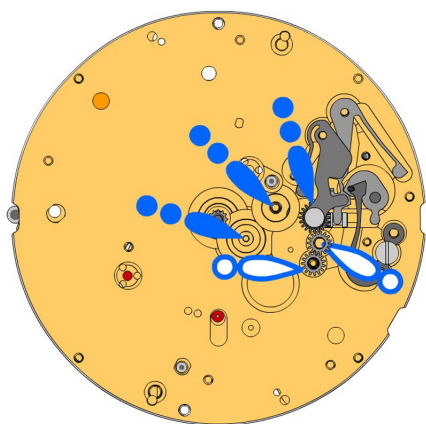

G

3015.077
36.  **Yoke (3 positions)**
Tensioning the spring arm.

3004.200
37.  **Corrector setting wheel**

3004.200
38.  **Corrector setting wheel**

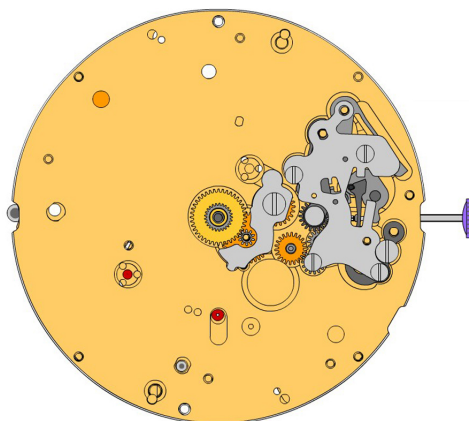
3015.078.CO
39.  **Rocking bar (3 positions)**
Tensioning the spring arm.

H

2130.194
40.  **Setting mechanism cover**
Setting mechanism cover held by 4 screws 4000.305.

4000.305
41.  **Screws**

3000.194.CO
42.  **Stem**

3004.204
43.  **Intermediate setting wheel**

3007.079.CO
44.  **Minute wheel**





2130.185
45.  **Minute train bridge**
Minute train bridge held by 1 screw 4000.278.

4000.278
46.  **Screw**

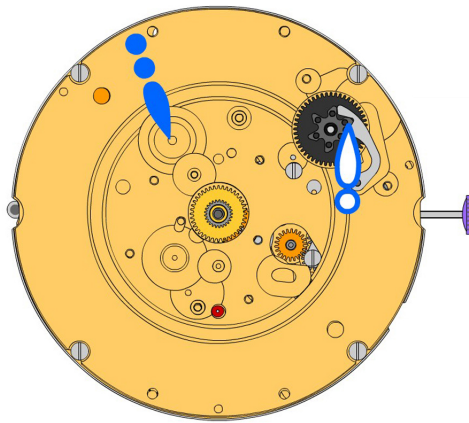



3301.296.CO
47.  **Hour wheel (Aig.1)**

3147.066.CO
48.  **Date corrector setting wheel**

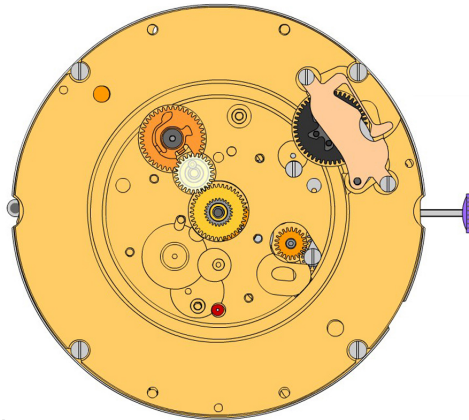



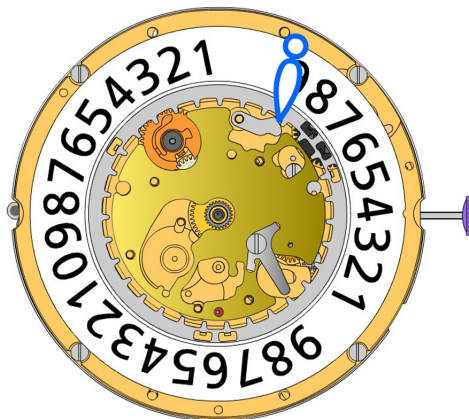

I

2000.671.G 49.		Main plate retro Main plate retro held by 4 screws 4000.248.
4000.248 50.		Screw
3004.209 51.		Tens indicator driving wheel The short tooth of the tens indicator driving wheel must point to the center of the movement.
3500.073 52.		Tens jumper

J



2130.187 53.		Tens jumper maintaining plate Tens jumper maintaining plate held by 2 screws 4000.279. Tensioning the spring arm.
4000.279 54.		Screw
3004.208.CO 55.		Date indicator driving wheel
3147.061 56.		Intermediate date wheel



K

2130.188 57.		Date indicator plate
3905.068 58.		Date corrector spring Date corrector spring held by 1 screw 4000.244.
3905.066 59.		Day rack lever spring Tensioning the spring arm.
3500.069 60.		Day jumper Tensioning the spring arm.
3500.068 61.		Date jumper
3504.229.AF.1.A 62.		Units indicator (standard) Nick of the indicator at 3 o'clock.



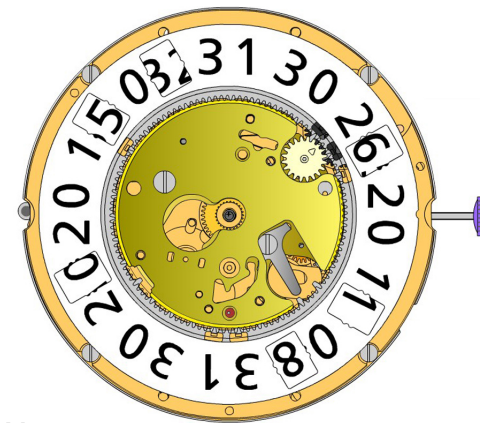

L

2130.189 63.		Date indicator maintaining plate Date indicator maintaining plate held by 1 screw 4000.250.
4000.250 64.		Screw
3905.064 65.		Date jumper spring Insert the date jumper spring in the provided opening.











M

3147.062 66.		Tens intermediate wheel Arrow positioning radially outwards.
3315.003 67.		Friction spring
3504.230.AF.1.A 68.		Tens indicator (standard) Nick of the indicator at 3 o'clock.



N

2130.190.G 69.		Date mechanism maintaining plate (12h) Date mechanism maintaining plate held by 3 screws 4000.320.
4000.320 70.		Screw
3506.077.G 71.		Intermediate dial support Polished version first.
3506.076.G 72.		Dial support

8200 73.		Moebius 8200
9014 74.		Moebius 9014
124 75.		Jismaa 124
9020 76.		Moebius 9020

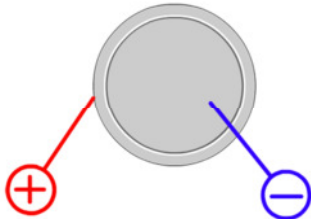

Battery	381
Voltage	1.55V

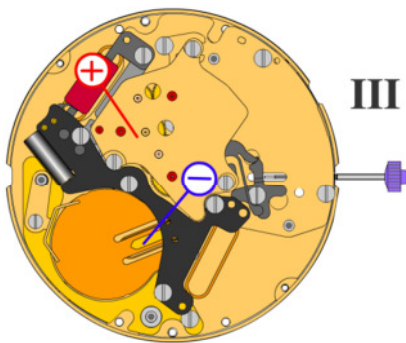
III

*Setting stem in position III,
60s measuring interval:*

Typical consumption	0.1 μA
Maximal consumption	0.3 μA

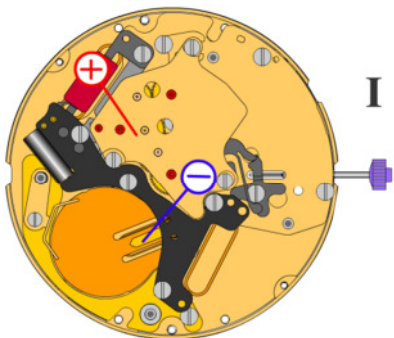
I

*Stem in position I, date
mechanism not in gear:*

Typical consumption	1.43 μA
Maximal consumption	3.1 μA

60s measuring time:

Instantaneous rate **-10s/mth .. +20s/mth**

Lower working voltage limit	1.20 V
-----------------------------	---------------